

-01 24" FLANGE MODIFICATION  
SCALE: 1/4

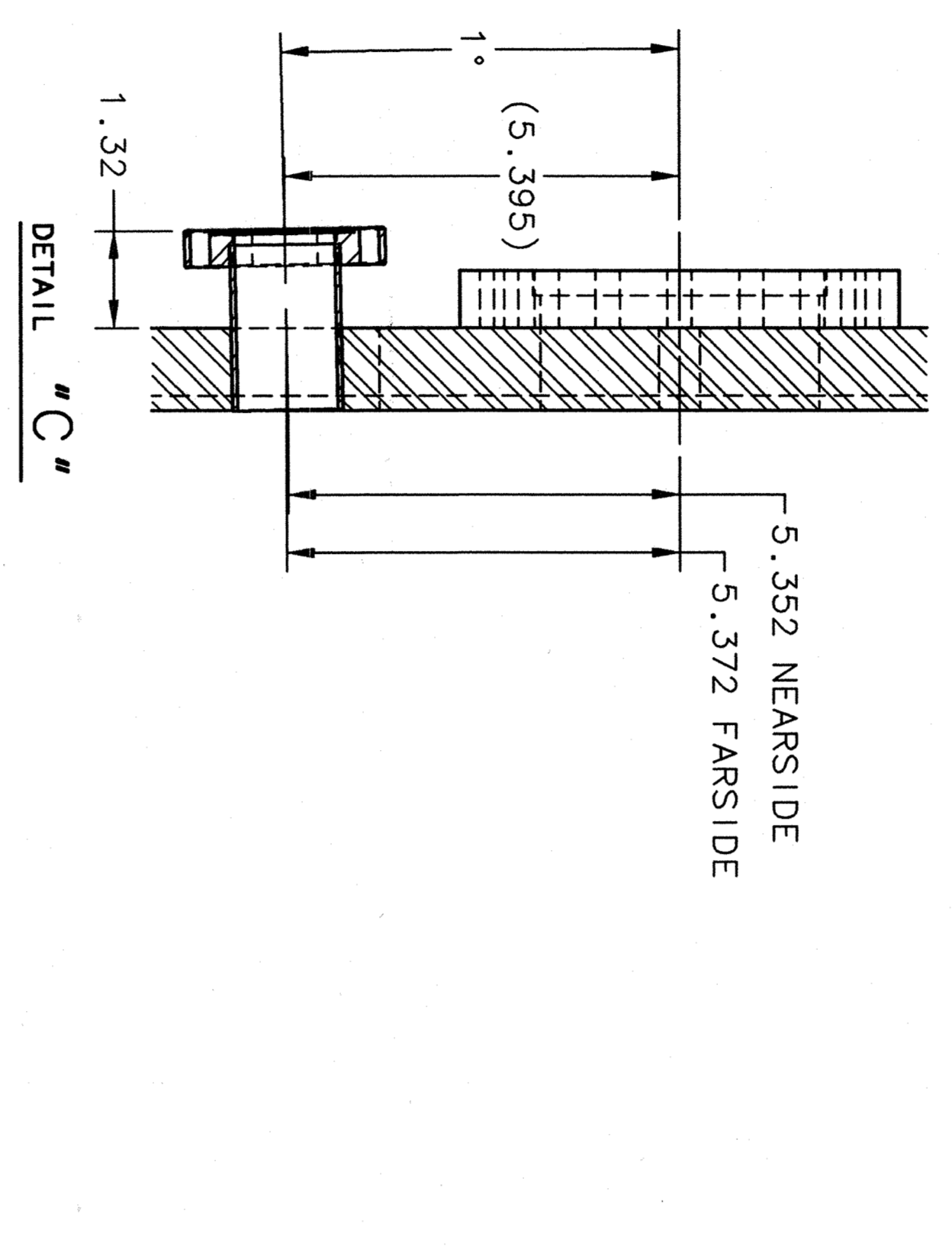

DETAIL "C"

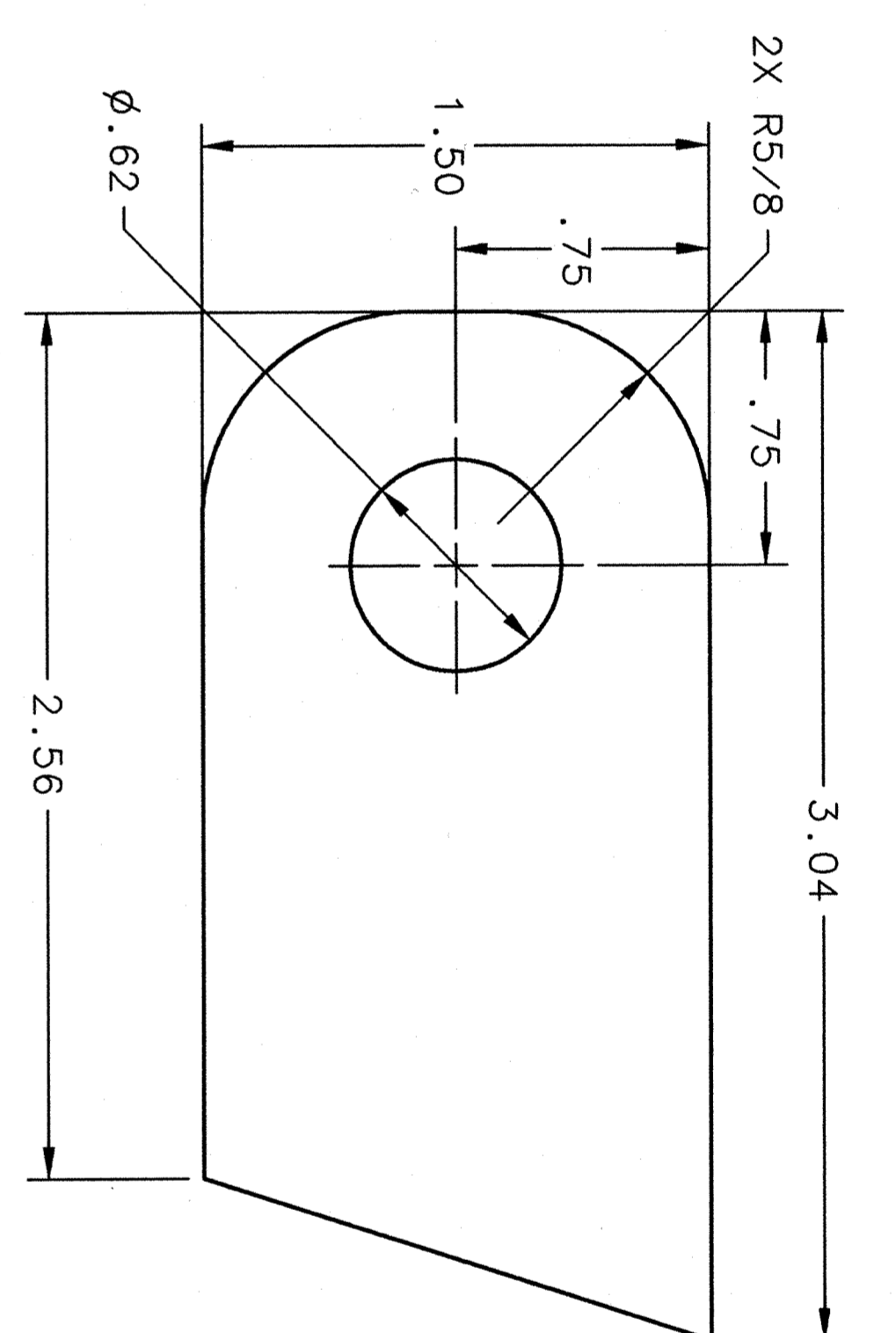

-04 SMALL HOLDER  
SCALE: 2/1

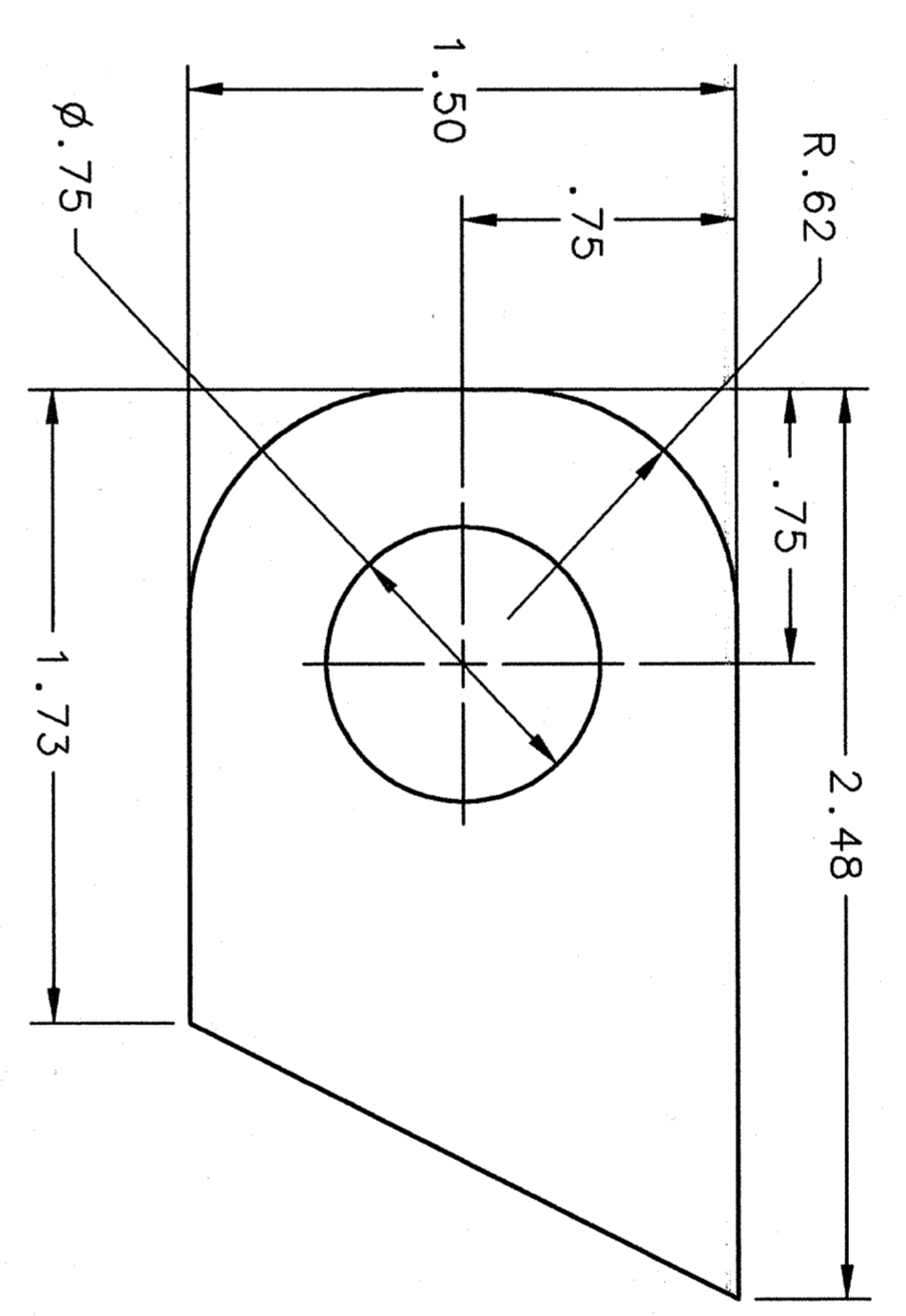
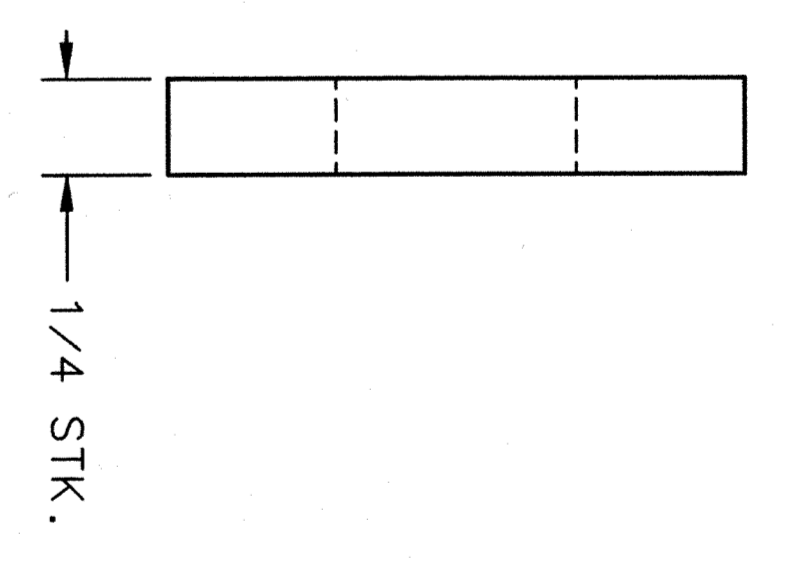

-05 LARGE HOLDER  
SCALE: 2/1

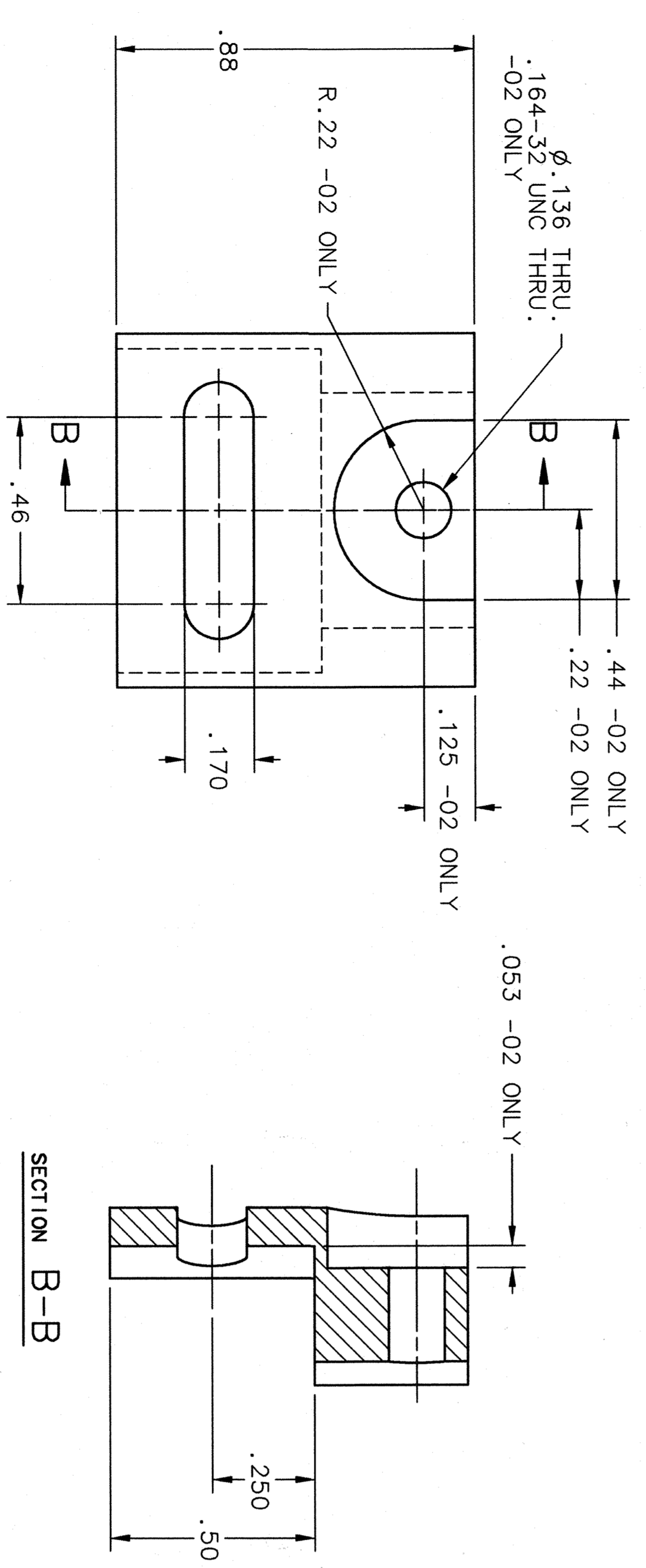
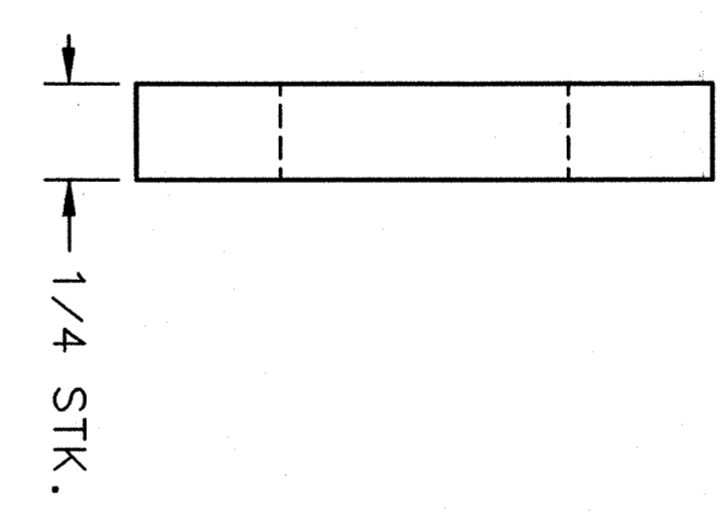

SECTION B-B

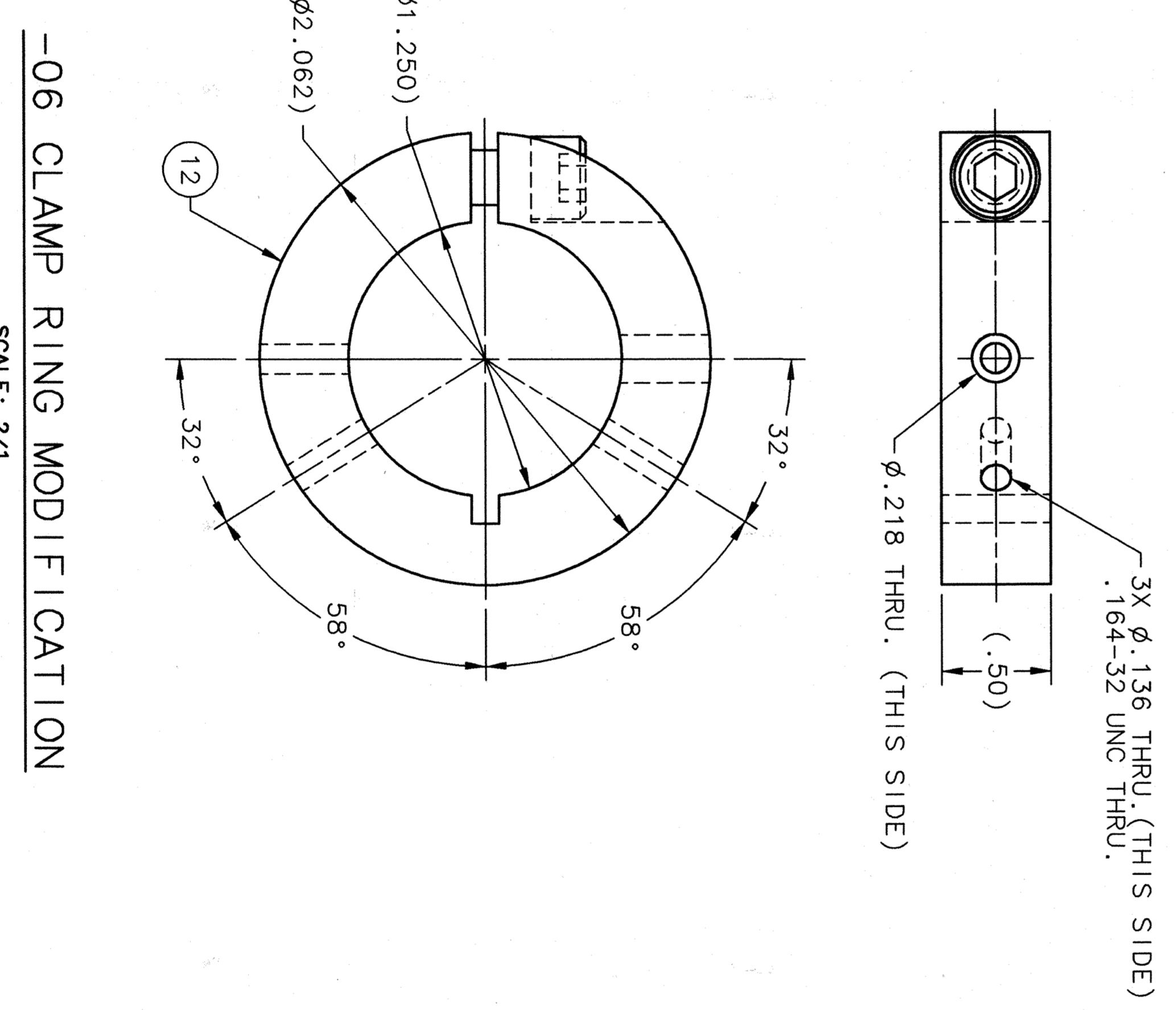

-06 CLAMP RING MODIFICATION  
SCALE: 2/1

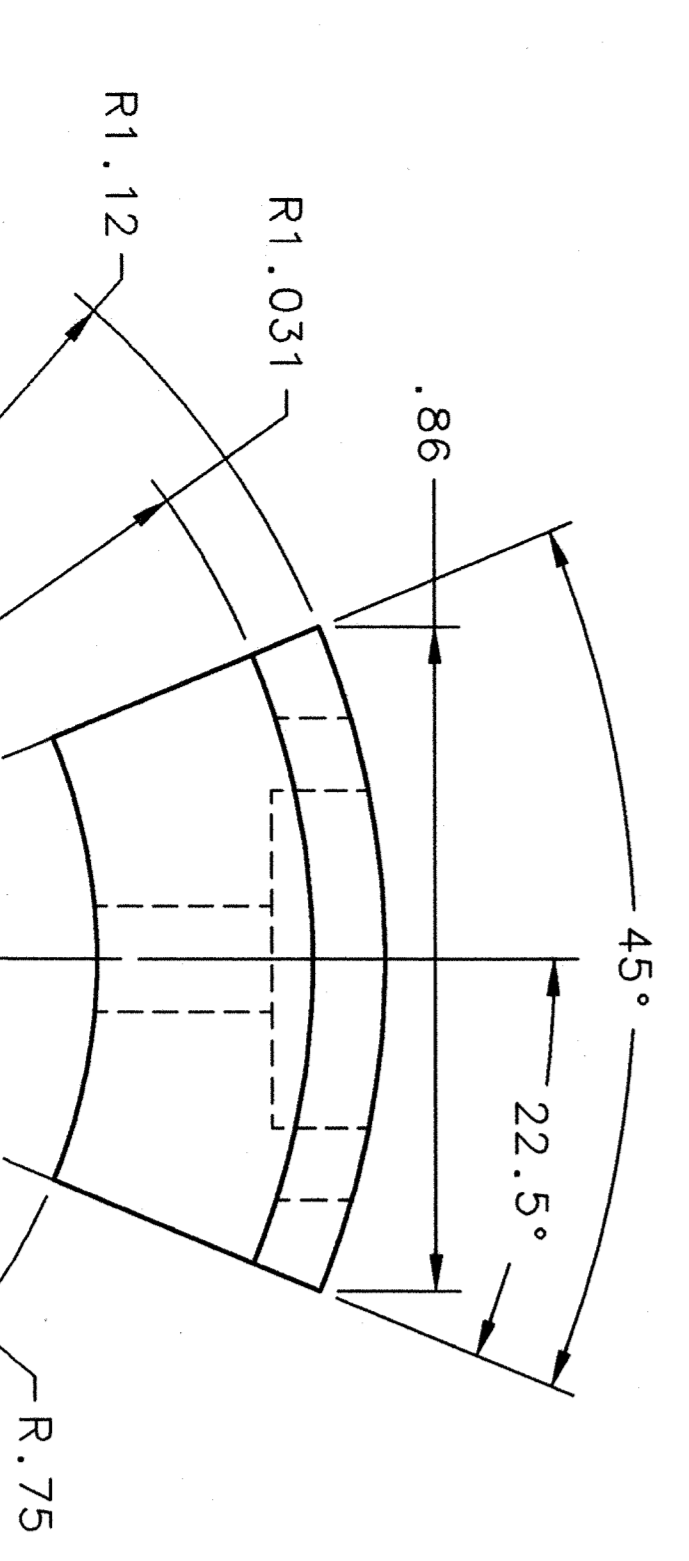

-02 STOP ADJUSTER W-LOCK SHOWN  
-03 STOP ADJUSTER SAME AS -02 EXCEPT AS SHOWN  
SCALE: 4/1

NOTE:

1. ALL PARTS MUST BE CLEANED, FREE OF GREASE, OIL OR OTHER CONTAMINANTS. SURFACES MUST BE SUITABLE FOR HIGH VACUUM SERVICE.

REV	DESCRIPTION	DATE	BY	CHKD
1	CLAMP RING ONE PIECE	7-22-06	WJG	WJG
2	2-3/4" CP HALF NIPPLE (TAPPED)	7-22-06	WJG	WJG
3	STOP BUSHING	7-22-06	WJG	WJG
4	STOP	7-22-06	WJG	WJG
5	SHORT TUBE WELDMENT	7-22-06	WJG	WJG
6	LONG TUBE WELDMENT	7-22-06	WJG	WJG
7	CLAMP RING MODIFICATION	7-22-06	WJG	WJG
8	LARGE HOLDER	7-22-06	WJG	WJG
9	SMALL HOLDER	7-22-06	WJG	WJG
10	STOP ADJUSTER	7-22-06	WJG	WJG
11	STOP ADJUSTER W-LOCK	7-22-06	WJG	WJG
12	24" OD. FLANGE MODIFICATION	7-22-06	WJG	WJG

APPROVALS DATE DOCUMENT CONTROL STATE

100%

NOTED

18% UNLESS SPECIFIED OTHERWISE ALL SURFACES ARE TO BE FINISHED TO THE FOLLOWING TOLERANCES UNLESS OTHERWISE SPECIFIED

± 1/32" ± 0.005" ± 0.002" ± 0.001" ± 0.0005"

THIRD ANGLE PROJECTION

DESIGNED BY: WJG DATE: 7-22-06

APPROVED BY: WJG DATE: 7-22-06

HALL C  
CZERO BACK ANGLE  
TARGET ASSEMBLY  
BACK ANGLE ASSEMBLY ITEMS  
672228-E-00006

SCALE: NOTED

SHEET 1 OF 2